

2.3.

Informazioni sul prodotto

Product informations

MCP/B

Apparecchiature dotate di apparato di filtrazione multistadio per il contenimento e l'aspirazione dell'overspray di verniciatura.

Equipments for the containment and the aspiration of the painting overspray, with multistage filtering system.





Descrizione

Unità autonome o da inserire in impianti di aspirazione centralizzati, dotate di filtrazione pluristadio, ad efficienza progressiva, prive di apparato di autopulizia a bordo.

Sono adatte, a seconda dell'equipaggiamento di filtri montato, all'impiego in presenza di polveri disperse ed overspray di verniciatura.

Costruzione

Le cabine MCP e MCB hanno robusta struttura a moduli autoportanti bullonati, fornibili anche in KIT di montaggio.

I pannelli sono realizzati in lamiera verniciata, preverniciata su supporto sendzimir o acciaio inox.

La sezione filtrante a 2 o 3 stadi sono realizzate con moduli unificati con caratteristiche dimensionali corrispondenti alla normativa internazionale, per assicurare un facile reperimento dei ricambi sul mercato.

Le sezioni trattano portate notevolmente ridotte rispetto alle potenzialità nominali di ciascun media, così da diradare gli interventi di manutenzione, e gli elementi filtranti sono predisposti in alloggiamenti normalizzati per una rapidissima sostituzione.

I moduli sono unificati, con caratteristiche dimensionali corrispondenti alla normativa internazionale, per assicurare un facile reperimento dei ricambi sul mercato.





Description

These units feature progressive efficiency multi-stage filtering without on-board self-cleaning device and can operate independently or be included in central extraction systems.

Depending on the filters fitted, they are suitable for use with dispersed dust and paint overspray.

Building

The MCP and MCB booths feature a sturdy structure consisting of bolted self-supporting modules and can also be supplied in assembly kits.

The panels are made of painted sheet metal, pre-painted on sendzimir or stainless steel support. The 2 or 3 stage filtering section consists of standard modules with dimensions corresponding to international regulations to ensure availability of spare parts.

The sections treat lower flow rates with respect to the rated capacity of each filtering medium, thus reducing maintenance operations, and the filtering elements are fitted in standardised housings for quick replacement.



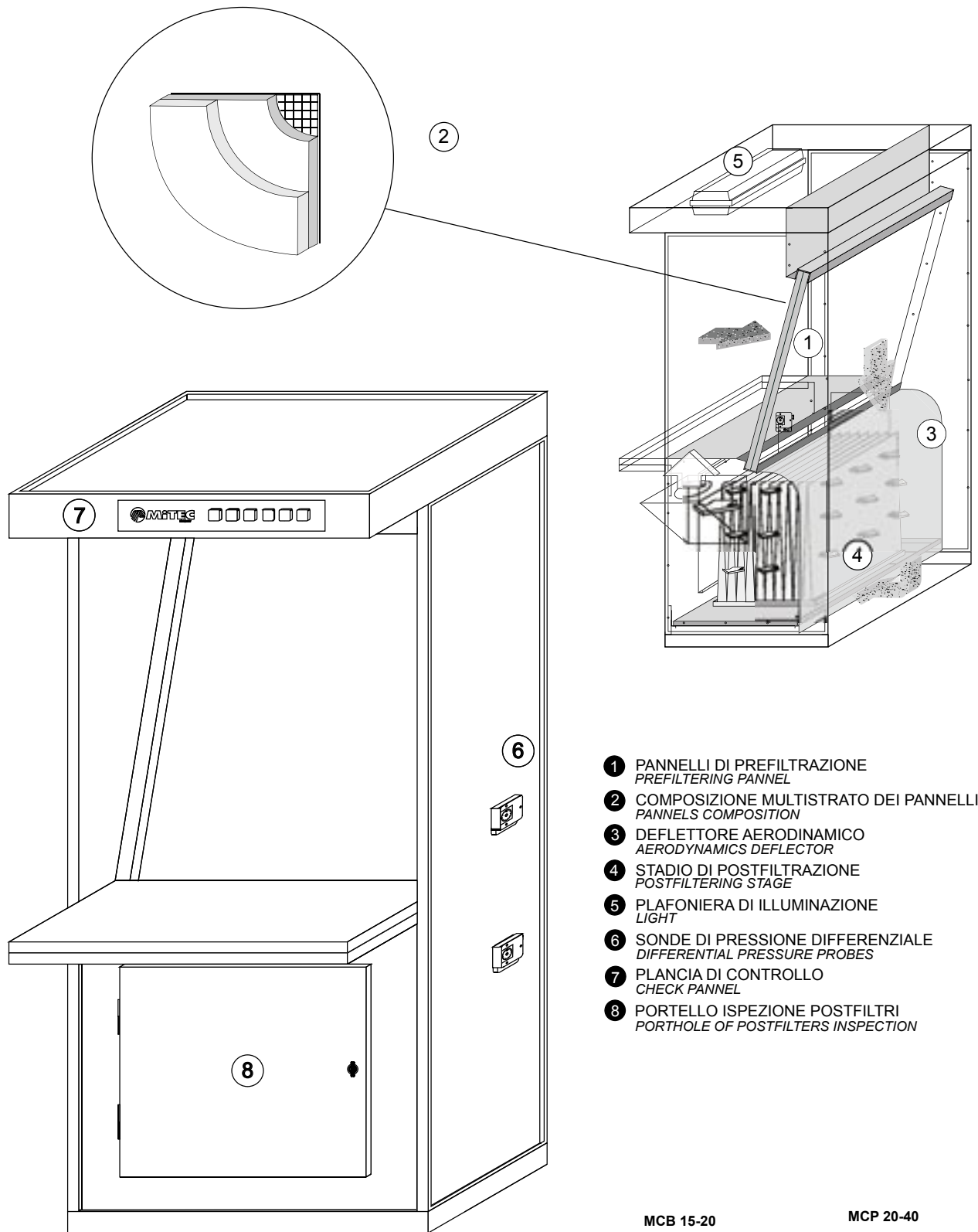

- ① PANNELLI DI PREFILTRAZIONE
PREFILTERING PANNEL
- ② COMPOSIZIONE MULTISTRATO DEI PANNELLI
PANELS COMPOSITION
- ③ DEFLETTORE AERODINAMICO
AERODYNAMICS DEFLECTOR
- ④ STADIO DI POSTFILTRAZIONE
POSTFILTERING STAGE
- ⑤ PLAFONIERA DI ILLUMINAZIONE
LIGHT
- ⑥ SONDE DI PRESSIONE DIFFERENZIALE
DIFFERENTIAL PRESSURE PROBES
- ⑦ PLANCIA DI CONTROLLO
CHECK PANNEL
- ⑧ PORTELLO ISPEZIONE POSTFILTRI
PORTHOLE OF POSTFILTERS INSPECTION

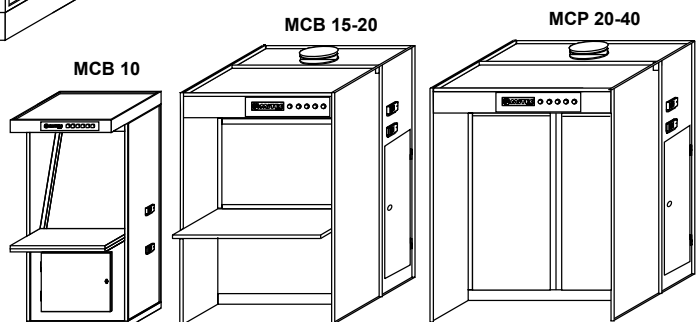



Cabina di verniciatura MCB 30 HE con banco aspirante
Painting booth mod. MCP 40 LHE with aspirant desk



Cabina di verniciatura MCP 30 LL HE con precamera mobile
Painting booth mod. MCP 30 LL HE with mobile prechamber

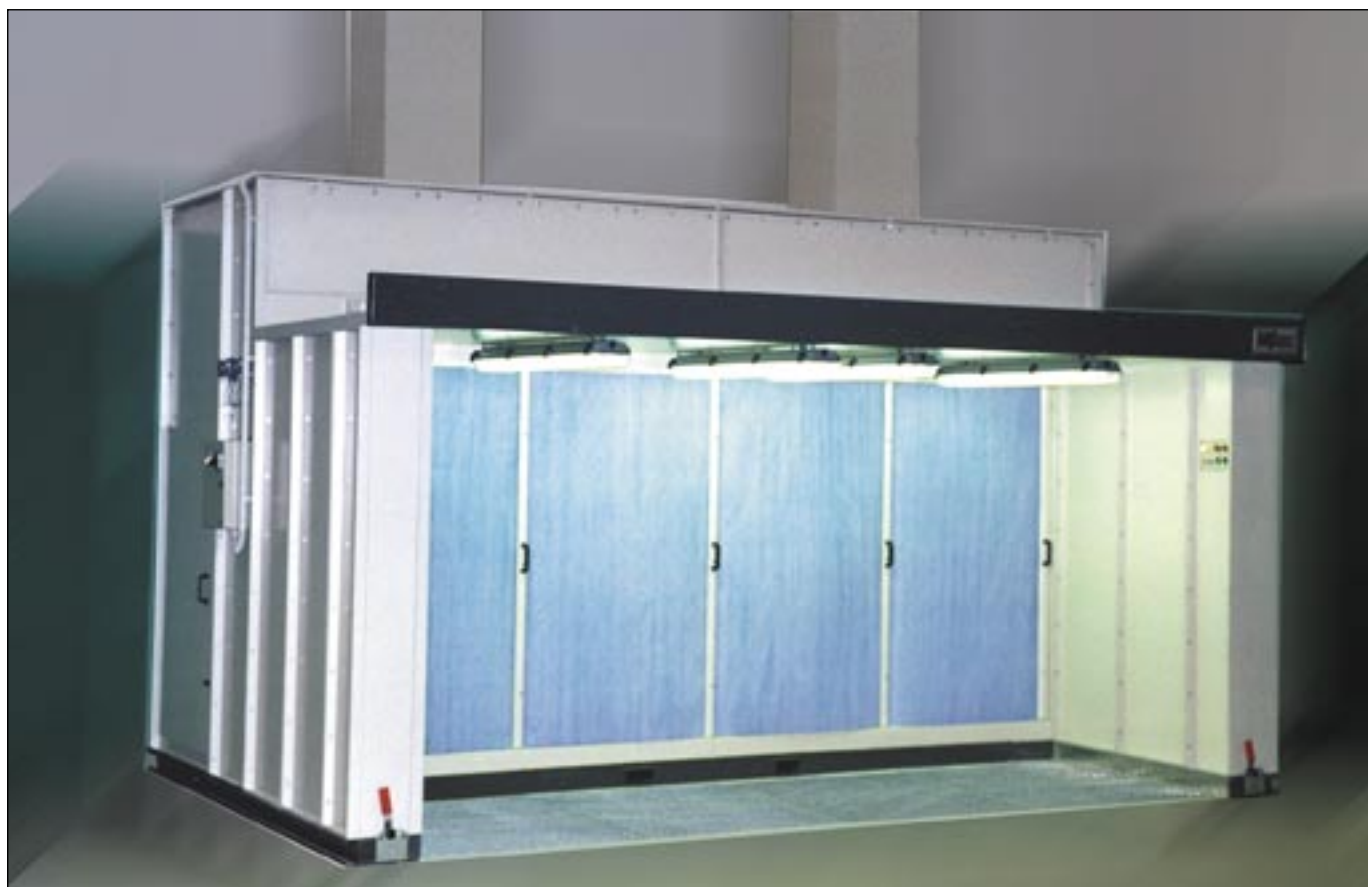

Cabina di verniciatura MCP 40 LHE con pavimento aspirante parzializzabile
Painting booth mod. MCP 40 LHE with divisible aspirant floor



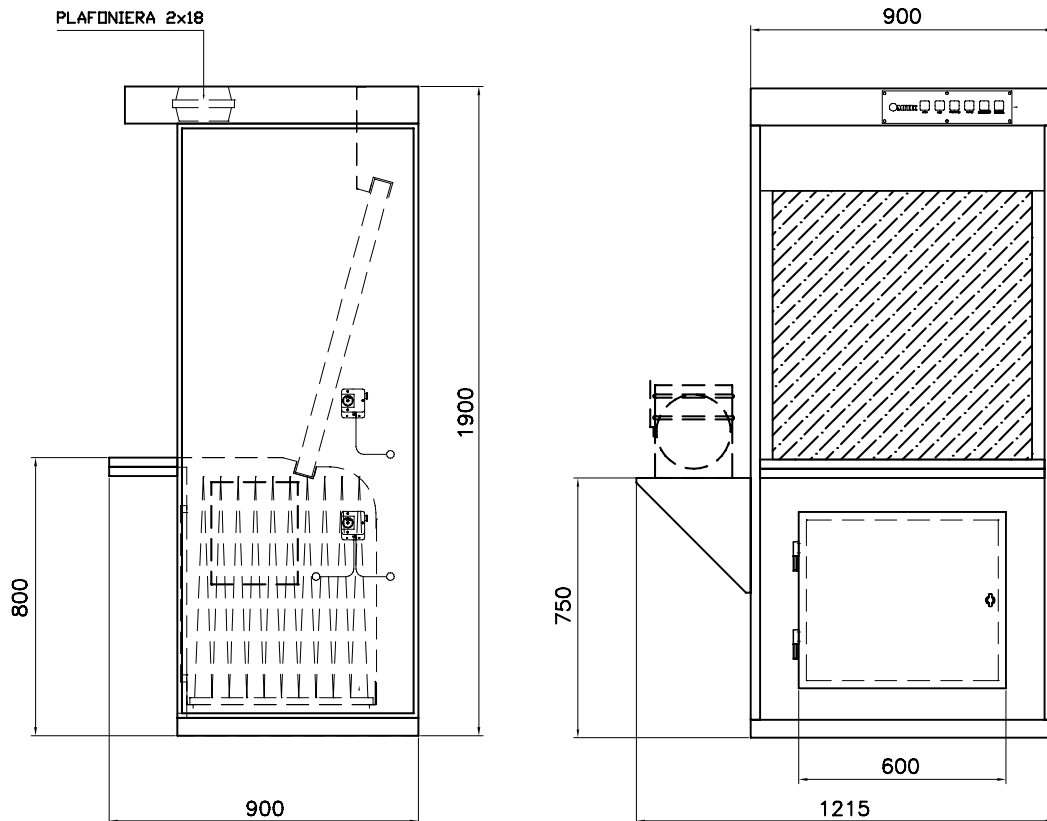

MCP10



CARATTERISTICHE TECNICHE/ TECHNICAL CHARACTERISTICS

apparecchiatura filtrante/ equipment:	multistadio/ <i>multistage</i>
stadi filtranti/ filtering stage:	MV 50 MB 20 MBA 59/59/60
efficienza di filtrazione/ filtering efficiency:	EU 8/9
materiale di costruzione/ body	lamiera di ferro al carbonio o zincata/ <i>in steel plate or sendzimir</i>
esecuzione/ structure:	pannelli autoportanti/ <i>in self-loading panels</i>
assemblaggio/ assembly:	bullonatura interna/ <i>by bolts only</i>
protezione superficiale/ panel protection:	verniciatura epossidica/ <i>by epoxy paints</i>
tinte di serie/ colors:	ral 7032 - 7035
portata/ flow-rate:	2000 Nmc/h
potenza installata/ power:	-
servizio/ use:	continuo/ <i>continuos</i>

ACCESSORI/ ACCESSORIES

- propulsore
propeller
- pressostati e spie luminose sul quadro elettrico
differential pressure-gauges and warning lights on the electrical board
- apparato di illuminazione
lights

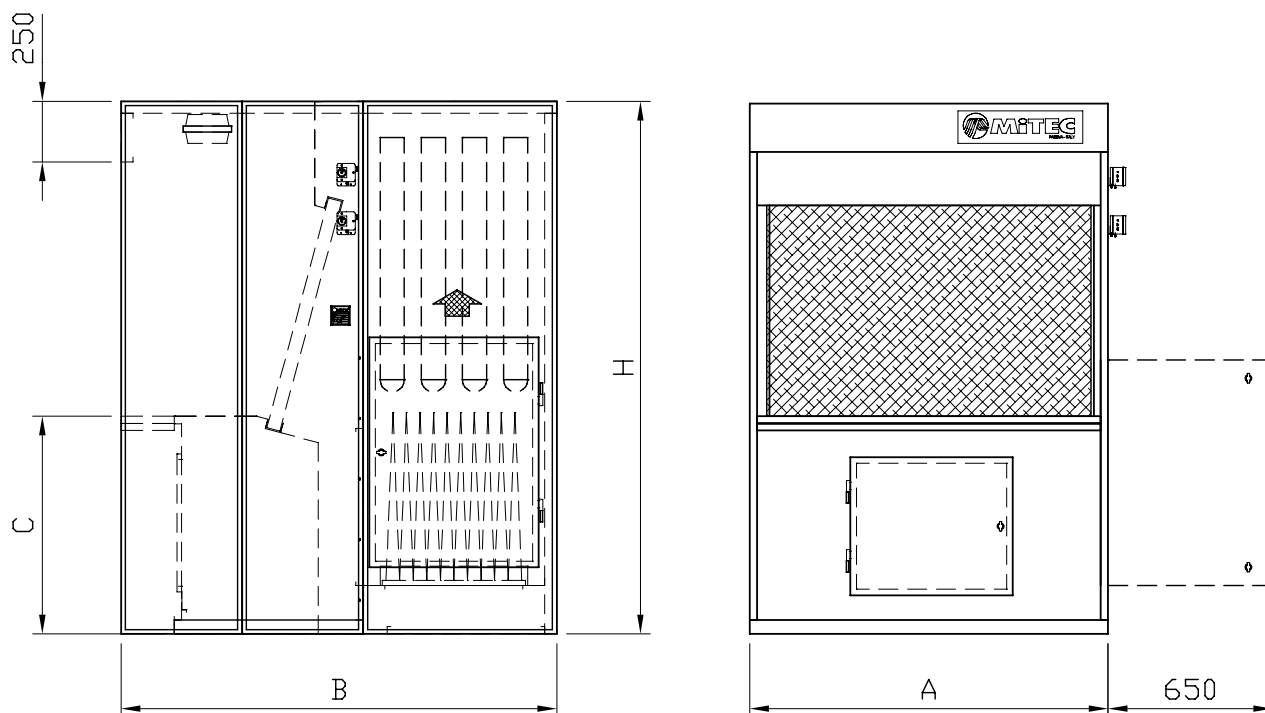

MOD.	15N	20N	30N	15HE	20HE	30HE
N° st.	2	2	2	3	3	3
A(mm)	1500	2100	3100	1500	2100	3100
B(mm)	1800	1800	1800	1800	1800	1800
H(mm)	2200	2200	2200	2200	2200	2200
C(mm)	800	800	800	800	800	800
IL.(W)	2x58	4x36	4x58	2x58	4x36	4x58
W(kg)	480	560	680	500	600	720

MCB

CARATTERISTICHE TECNICHE/ TECHNICAL CHARACTERISTICS
apparecchiatura filtrante/ equipment:
stadi filtranti/ filtering stage:

 multistadio/ *multistage*

MV 50

MB 20

MBA 59/59/763 (HE)

EU3 (N) - EU 8/9 (HE)

efficienza di filtrazione/ filtering efficiency:
materiale di costruzione/ body

 lamiera di ferro al carbonio o zincata/ *in steel plate or sendzimir*
esecuzione/ structure:

 pannelli autoportanti/ *in self-loading panels*
assemblaggio/ assembly:

 bullonatura interna/ *by bolts only*
protezione superficiale/ panel protection:

 verniciatura epossidica/ *by epoxy paints*
tinte di serie/ colors:

ral 7032 - 7035

portata/ flow-rate:

-

potenza installata/ power:

-

servizio/ use:

 continuo/ *continuos*
ACCESSORI/ ACCESSORIES

- propulsore
propeller
- pressostati e spie luminose sul quadro elettrico
differential pressure-gauges and warning lights on the electrical board
- silenziatore assorbitivo MSA
silencer MSA
- apparato di illuminazione
lights

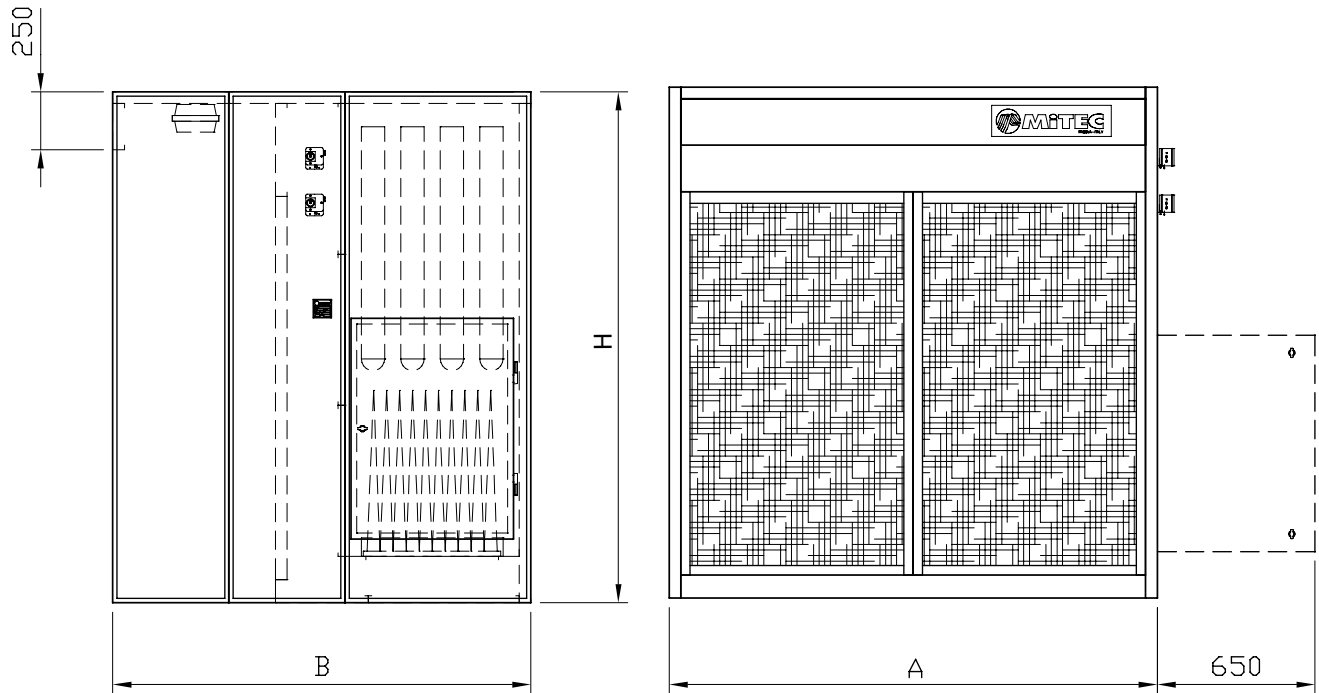

MOD.	20N	30N	40N	20HE	30HE	40HE
N° st.	2	2	2	3	3	3
A(mm)	2100	3100	4000	2100	3100	4000
B(mm)	1800	1800	1800	1800	1800	1800
H(mm)	2200	2200	2200	2200	2200	2200
IL.(W)	2x58	4x36	4x58	2x58	4x36	4x58
W(kg)	500	600	800	520	640	850

MCP

CARATTERISTICHE TECNICHE/ TECHNICAL CHARACTERISTICS

apparecchiatura filtrante/ equipment:
stadi filtranti/ filtering stage:

multistadio/ *multistage*

MV 50

MB 20

MBA 59/59/763 (HE)

EU3 (N) - EU 8/9 (HE)

efficienza di filtrazione/ filtering efficiency:

materiale di costruzione/ body

esecuzione/ structure:

assemblaggio/ assembly:

protezione superficiale/ panel protection:

tinte di serie/ colors:

portata/ flow-rate:

potenza installata/ power:

servizio/ use:

lamiera di ferro al carbonio o zincata/ *in steel plate or sendzimir*

pannelli autoportanti/ *in self-loading panels*

bullonatura interna/ *by bolts only*

verniciatura epossidica/ *by epoxy paints*

ral 7032 - 7035

-

-

continuo/ *continuos*

ACCESSORI/ ACCESSORIES

- propulsore
propeller
- pressostati e spie luminose sul quadro elettrico
differential pressure-gauges and warning lights on the electrical board
- silenziatore assorbitivo MSA
silencer MSA
- apparato di illuminazione
lights

MITEC srl
Via Svizzera; 14 - Z.I. Camin
35127 PADOVA- ITALY
Tel: +39-49-8705366 r.a.
Fax +39-49-8705786
Internet: www.mitecsrl.com
Email: mitec@mitecsrl.com

